

[accurat]

SPORT

GEL TECHNOLOGY



YTX7L-BS

7Ah | 12V | 130A

Electrical Specifications

Nominal voltage	12V
Nominal capacity (25°C)	7Ah at 10h
CCA -18 °C	130A

Retention of Charge During Storage at 25°C		
1 month	97%	Directly mounted
3 months	90%	Directly mounted
6 months	80%	Constant voltage: 14.4V Limit current: 1.4A Charging time: 2 - 3h
12 months	40%	Constant voltage: 14.4V Limit current: 1.4A Charging time: 4 - 6h

Mechanical Specifications

Measurements (L x W x H)	113 x 70 x 132mm
Weight	2.15kg
Storage status	Wet
Cover	ABS
Terminal	C3
Container bottom	ABS
Positive plate	PbO ₂
Negative plate	Pb
Separator	AGM
Electrolyte	Diluted sulphuric acid
Safety valve	Rubber
Way of sealing	Epoxy resin

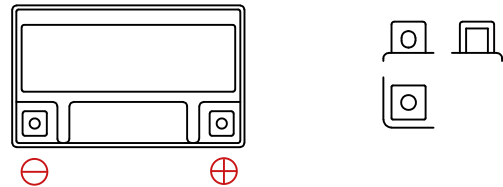
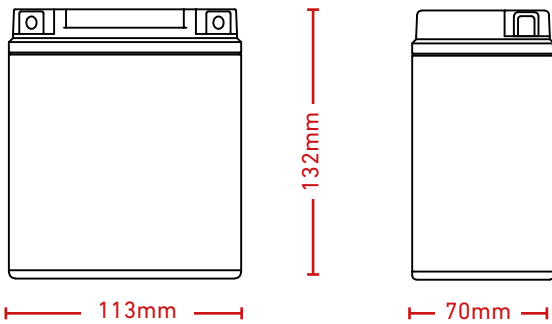

Discharge Current 25 °C

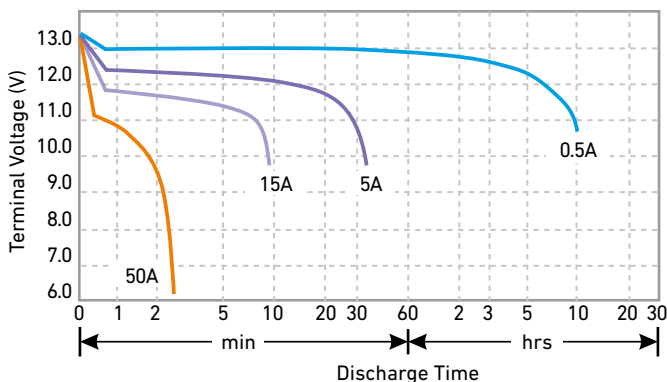

Residual Capacity

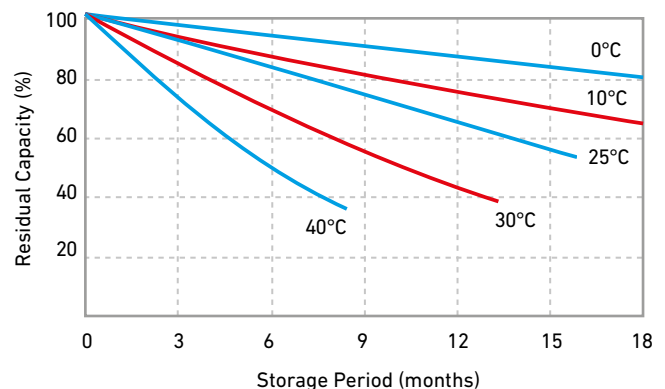

batterium GmbH | Robert-Bosch-Straße 1
71691 Freiberg am Neckar | Germany
T: +49 7141 / 560 90 40